



Public Works Department

290 E. Linden, Chubbuck, ID 83202
208.237.2430 – Fax 208.237.2409
www.CityofChubbuck.us

APPLICATION AND PERMIT TO USE RIGHT-OF-WAY

OWNER:

CONTRACTOR:

Name / Firm

Name / Firm.

Mailing Address

R-O-W License No.

ESC Certificate No.

Telephone

Email

Telephone

Email

SITE ADDRESS:

DESCRIPTION OF WORK:

TYPE OF WORK:
Other

Overhead

Underground

Roadway Cut

START DATE:

ESTIMATED COMPLETION DATE:

2024 PERMIT FEE: \$25.00

PMNT REC'VD BY:

DATE:

THE FOLLOWING MUST ACCOMPANY THIS APPLICATION:

- Detailed plan showing pertinent information (legible)
Erosion and Sediment Control permit application, associated fee, plan and narrative explaining the implementation of Best Management Practices.
Detailed traffic control plan in accordance with MUTCD standards.

I, certify that I am the authorized owner and/or utility company representative and request permission to construct, reconstruct, repair the above facilities within the City of Chubbuck street right-of-way in accordance with City Code, the general provisions printed on the reverse side of this form and the plans / special provision made a part of this permit.

Signature of Applicant:

Date:

PERMIT #:

This permit is hereby approved and issued in accordance with City of Chubbuck Code requirements

City Engineer or Authorized Representative

Date

Completion Inspection Date

Warranty Expiration Date

## GENERAL PROVISIONS

CONSTRUCTION PLANS SHALL BE LEGIBLE SHOWING SUCH ITEMS AS, BUT NOT LIMITED TO:

- IDENTIFY ALL EXISTING UTILITIES ON THE PLAN
- IDENTIFY PROPOSED WORK ON THE PLAN
  - o INCLUDE TRENCHING DETAILS, BURY DEPTH, SURFACE RESTORATION
- PROVIDE 18" MINIMUM VERTICAL SEPERATION FROM ALL CITY INFRASTRUCTURE

CONTRACT SHALL BE RESONSIBLE FOR:

- NOTIFICATIONS FOR INSEPCIONS
- DIGLINE LOCATES PER IDAHO CODE
- REFERENCING AND RESTORING EXISTING SURVEY MONUMENTS PER IDAHO CODE
- SUBMISSION OF RECORD DRAWINGS

DURING THE PROGRESS OF THE WORK SUCH BARRICADES, LIGHTS AND OTHER TRAFFIC CONTROL DEVICES SHALL BE ERECTED AND MAINTAINED AS MAY BE NECESSARY OR AS MAY BE DIRECTED FOR THE PROTECTION OF THE TRAVELING PUBLIC. SAID BARRICADES, LIGHTS AND OTHER TRAFFIC CONTROL DEVICES SHALL CONFORM TO THE CURRENT ISSUE OF THE MANUAL ON UNIFORM TRAFFIC CONTROL DEVICES FOR STREETS AND HIGHWAYS. PARKED EQUIPMENT AND STORED MATERIALS SHALL BE AS FAR FROM THE TRAVEL WAY AS FEASIBLE. ITEMS KEPT OVER NIGHT WITHIN THIRTY FEET (30 FT.) OF TRAVEL WAY SHALL BE MARKED AND/OR PROTECTED.

IN ACCEPTING THIS PERMIT, THE PERMITTEE AND ITS SUCCESSORS AND ASSIGNS AGREE TO HOLD THE CITY OF CHUBBUCK HARMLESS FROM ANY AND ALL LIABILITY ON ACCOUNT OF THE ERECTION, INSTALLATION, CONSTRUCTION, MAINTENANCE OR OPERATION OF THE FACILITIES LOCATED PURSUANT TO THIS PERMIT AND HOLD THE CITY HARMLESS FROM ALL WORK DONE BY PERMITTEE PURSUANT TO THIS PERMIT. PERMITTEE SHALL CARRY IN FORCE GENERAL PUBLIC LIABILITY INSURANCE COVERAGE IN AN AMOUNT OF NOT LESS THAN **ONE MILLION DOLLARS (\$1,000,000) PER OCCURRENCE**. THE **CITY SHALL BE NAMED AS ADDITIONAL INSURED** UNDER THE POLICY. THE CITY SHALL ALSO BE PROVIDED NOTICE OF CANCELLATION BY THE INSURANCE COMPANY TO THE CITY IF COVERAGE IS CANCELLED. THE CITY SHALL BE PROVIDED A CERTIFICATE OF INSURANCE COVERAGE AT THE TIME OF FILING.

EXCEPT AS HEREIN AUTHORIZED, ALL UNDERGROUND CROSSINGS SHALL BE BORED OR JACKED. NO EXCAVATION SHALL BE MADE NOR OBSTACLES PLACED WITHIN THE RIGHT-OF-WAY OF THE CITY STREET IN SUCH A MANNER AS TO INTERFERE WITH TRAVEL OVER SAID STREET. THE PERMITTEE'S CONTRACTOR MUST NOTIFY THE CITY NOT MORE THAN SEVEN (7) DAYS NOR LESS THAN ONE (1) DAYS PRIOR TO COMMENCING CONSTRUCTION.

ANY DISTURBANCE OF THE ROADWAY TRAVELED SURFACE, TRAFFIC CONTROL DEVICES, CURB OR SIDEWALK SHALL BE RESTORED TO THE SATISFACTION OF THE CITY ENGINEER. EXCAVATIONS SHALL BE BACKFILLED WITH SUITABLE MATERIAL COMPACTED TO THE STANDARDS SPECIFIED IN THE IDAHO STANDARDS FOR PUBLIC WORKS CONSTRUCTION. PAVEMENT SHALL BE RESTORED WITHIN TWENTY-FOUR (24) HOURS OF THE PROJECT COMPLETION.

IF WORK DONE UNDER THIS PERMIT INTERFERES IN ANY WAY WITH THE DRAINAGE OF THE CITY STREET, THE PERMITTEE SHALL WHOLLY AND AT HIS OWN EXPENSE MAKE SUCH PROVISION AS THE CITY ENGINEER MAY DIRECT TO RESTORE SAID DRAINAGE.

ON COMPLETION OF SAID WORK HEREIN CONTEMPLATED ALL MUD AND WASTE SHALL BE IMMEDIATELY REMOVED AND THE ROADWAY AND ROADSIDE SHALL BE LEFT NEAT AND PRESENTABLE TO THE SATISFACTION OF THE CITY ENGINEER.

ALL OF THE WORK HEREIN CONTEMPLATED SHALL BE DONE TO CONFORM WITH CURRENT GOVERNMENT AND INDUSTRY STANDARDS INCLUDING, BUT NOT LIMITED TO "A POLICY FOR THE ACCOMMODATION OF UTILITIES WITHIN THE RIGHT-OF-WAY OF THE STATE HIGHWAY SYSTEM IN THE STATE OF IDAHO" AS PROMULGATED BY THE STATE OF IDAHO TRANSPORTATION DEPARTMENT. THE WORK SHALL ALSO BE DONE UNDER THE SUPERVISION AND TO THE SATISFACTION OF THE CITY ENGINEER AND THE ENTIRE EXPENSE OF SAID SUPERVISION SHALL BE BORNE BY THE PERMITTEE.

THE CITY OF CHUBBUCK HEREBY RESERVES THE RIGHT TO ORDER THE CHANGE OF LOCATION OR THE REMOVAL OF ANY STRUCTURE(S) OR FACILITY(IES) AUTHORIZED BY THIS PERMIT. SAID CHANGE OR REMOVAL TO BE MADE AT THE SOLE EXPENSE OF THE PERMITTEE, OR ITS SUCCESSORS AND ASSIGNS, UNLESS SUCH STRUCTURE(S) OR FACILITY(IES) HAVE BEEN LOCATED PURSUANT TO THE SPECIAL PROVISIONS.

ALL SUCH CHANGES, RECONSTRUCTION OR RELOCATION BY THE PERMITTEE SHALL BE DONE IN SUCH A MANNER AS WILL CAUSE THE LEAST INTERFERENCE WITH ANY OF THE CITY'S WORK.

THIS PERMIT OR PRIVILEGE GRANTED SHALL NOT BE DEEMED OR HELD TO BE AN EXCLUSIVE ONE AND SHALL NOT PROHIBIT THE CITY FROM GRANTING OTHER PERMITS OR FRANCHISE RIGHTS OF LIKE OR OTHER NATURE TO OTHER PUBLIC OR PRIVATE UTILITIES, NOR SHALL IT PREVENT THE CITY FROM USING ANY OF ITS ROADS, STREETS, OR PUBLIC PLACES, OR AFFECT ITS RIGHT TO FULL SUPERVISION AND CONTROL OVER ALL OR ANY PART OF THEM, NONE OF WHICH IS HEREBY SURRENDERED.

THE CITY MAY REVOKE, AMEND, AMPLIFY, OR TERMINATE THIS PERMIT OR ANY OF THE CONDITIONS HEREIN ENUMERATED IF PERMITTEE FAILS TO COMPLY WITH ANY OR ALL OF ITS PROVISIONS, REQUIREMENTS OR REGULATIONS AS HEREIN SET FORTH OR THROUGH WILLFUL OR UNREASONABLE NEGLIGENCE, FAILS TO HEED OR COMPLY WITH NOTICES GIVEN, OR IF THE UTILITY HEREIN GRANTED IS NOT INSTALLED OR OPERATED AND MAINTAINED IN CONFORMITY HERewith.

THE PERMITTEE SHALL MAINTAIN AT ITS SOLE EXPENSE THE STRUCTURE OR SUBJECT FOR WHICH THIS PERMIT IS GRANTED.

ADEQUATE DRAWINGS OR SKETCHES SHALL BE INCLUDED SHOWING THE EXISTING AND/OR PROPOSED LOCATION OF THE FACILITY WITH RESPECT TO THE EXISTING AND/OR PLANNED LOCATION OF THIS STREET IMPROVEMENT, THE TRAVELED WAY, THE RIGHTS OF WAY LINES, AND WHERE APPLICABLE, THE CONTROL OF ACCESS LINES AND APPROVED ACCESS POINTS.

IF TRENCH OR PAVEMENT SETTLEMENT SHOULD OCCUR WITHIN THREE (3) YEARS FROM THE DATE OF INSTALLATION, REPAIRS SHALL BE MADE BY THE PERMITTEE AS DIRECTED BY THE CITY ENGINEER AT NO COST TO THE CITY. IF THE PERMITTEE FAILS TO MAKE THE NECESSARY REPAIRS, THE CITY WILL MAKE THE REPAIRS AND BILL THE PERMITTEE. NO NEW PERMITS SHALL BE ISSUED TO THE PERMITTEE UNTIL SUCH CLAIM HAS BEEN SETTLED.

A CONTRACTOR'S SURETY BOND IN THE AMOUNT OF **TEN THOUSAND (\$10,000)** IS REQUIRED FOR THE PROTECTION OF THE CITY AS SET FORTH IN THE TERMS OF THE BOND. BOND AMOUNT MAY BE INCREASED BY THE CITY ENGINEER IF DEEMED NECESSARY FOR THE PROTECTION OF THE CITY.

ANY REPLACEMENT OF, ADDITION TO, OR CHANGE IN THE FACILITY GRANTED BY THIS PERMIT SHALL REQUIRE A NEW PERMIT PRIOR TO INITIATION OF SUCH WORK.



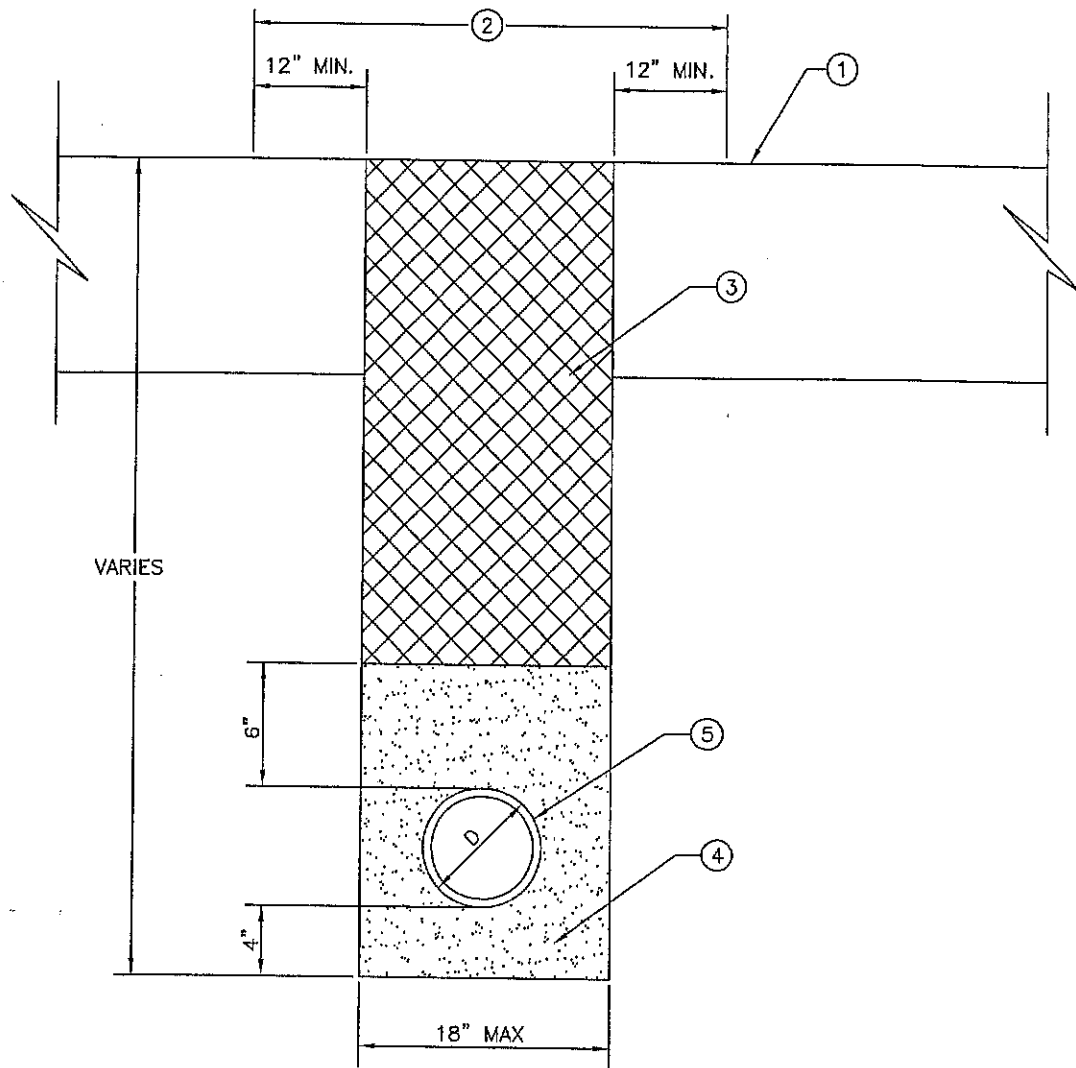

**NOTES**

- (A) USE THIS DETAIL FOR POTHOLES OVER ALL UTILITIES.
- (B) SAWCUT ALL ASPHALT IN NEAT LINES.

**LEGEND**

- (1) FINISH GRADE.
- (2) SEAL COAT W/CLASS 4 COVER PER SECTION-808 OF THE IDAHO STANDARDS FOR PUBLIC WORKS CONSTRUCTION.
- (3) FLOWABLE FILL BACKFILL PER SECTION-703 OF THE IDAHO STANDARDS FOR PUBLIC WORKS CONSTRUCTION.
- (4) 3/4" MINUS CRUSHED AGGREGATE OR SAND BEDDING.
- (5) PIPE OR CONDUIT.



## Public Works Department

290 E. Linden, Chubbuck, ID 83202

208.237.2430 – Fax 208.237.2409

[www.CityofChubbuck.us](http://www.CityofChubbuck.us)

### CITY INFRASTRUCTURE PROTECTION

Form to be signed only by the permit holder

Initial

\_\_\_\_\_ Lots and properties within the City of Chubbuck typically include, or are near, municipal infrastructure such as sewer, water, secondary irrigation, and streets.

\_\_\_\_\_ All excavation and grading work performed within the State of Idaho requires compliance with laws governing Digline (1-800-342-1585) prior to performing any work.

\_\_\_\_\_ Best management practices shall be taken by the permit holder to protect all City infrastructure to ensure that municipal utilities are not damaged during the construction process.

\_\_\_\_\_ In the event that any City infrastructure is damaged at any time during the process by the permit holder, suppliers, subcontractors, or any other agent of the permit holder, it is the permit holder's responsibility to notify the City of the event's details as soon as possible. The City will repair the damage and the permit holder shall be assessed all costs of repair, which shall include materials, labor, and other associated costs. In the event that the permit holder fails to pay the assessment, the City may issue a Stop Work order on the site until remedy is provided, or pursue other methods legally available to the City.

\_\_\_\_\_ No permit holder is authorized to make any modification to any infrastructure's placement or location, including irrigation boxes and lines, unless specifically authorized by the City and with the necessary inspections.

I, the undersigned, certify that I have read this form and aware of my responsibilities and obligations herein listed.

\_\_\_\_\_  
Print Name

\_\_\_\_\_  
Signature

\_\_\_\_\_  
Date